

HEAT TRANSFER IN A DISC-TYPE DSC APPARATUS. I. EXPERIMENTAL

P. CLAUDY, J.C. COMMERCON * and J.M. LETOFFE

Laboratoire de Thermochimie Minérale associé au C.N.R.S. No. 116, Institut National des Sciences Appliquées de Lyon, 69621 Villeurbanne Cedex (France)

(Received 17 December 1982)

ABSTRACT

Heat transfer in a disc-type DSC apparatus has been studied. Experimental results are interpreted qualitatively. Sample and reference crucibles exchange a heat flow during a thermal effect. A detailed model of heat exchange has to be made to obtain a correct interpretation of the calorimetric signal on the basis of data obtained.

INTRODUCTION

Differential scanning calorimetry is widely used and the literature abounds with papers dealing with its application in a broad area: characterization of compounds, phase diagrams, purity determination. Many equations have been developed using the calorimetric signal Δ . However, several workers [1,2] have pointed out that this signal is not representative of the true thermal effect occurring in the crucible and they have proposed mathematical methods for its correction. Two different methods have emerged:

(i) a known signal (Joule effect), S , is applied to the crucible and related to the output signal Δ . The function $\Delta = f(S)$ is established and used for the computation of the true thermal effect (black box approach);

(ii) using the thermal Ohm's law, an electrical representation of the calorimeter is established, and using an analog [3] or numeric computer, the Δ signal gives S [4] (model approach).

The second method, based on the mechanical design of the calorimeter seems more suitable, particularly if the basic conception of the calorimeter system were revised [5].

The disc-type apparatus, often called Boersma DSC [6] and made commercially available by Mettler or Dupont, is shown in Fig. 1. It is basically

* Laboratoire d'Informatique Appliquée.

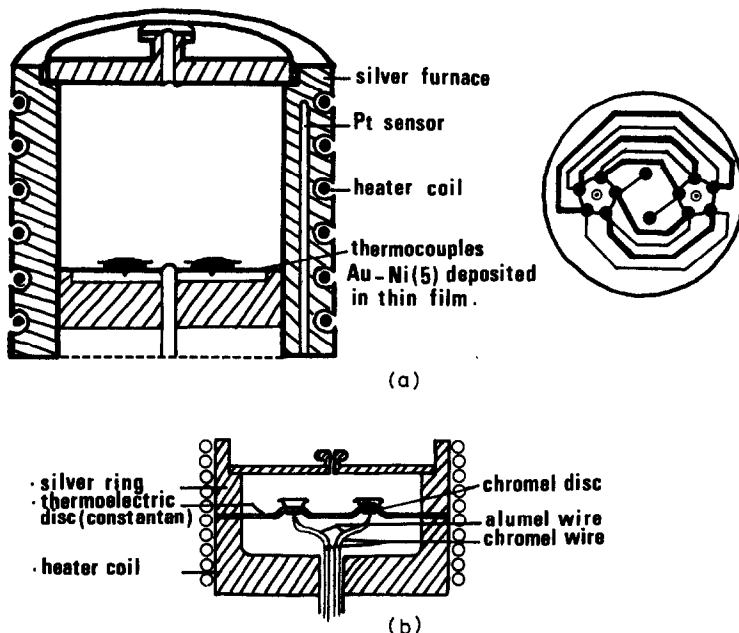

Fig. 1. Cross-section of the DSC cell. (a) Mettler TA 2000; ———, Ni; ———, Au. (b) DuPont 910.

described by the same equations as for a Calvet-type microcalorimeter, assuming that heat transfer between the crucible and the furnace occurs through the plate P bearing the crucible and the thermocouples. But it is known that the same thermal effect (melting of a pure substance) does not give the same signal if the surrounding gas is changed. Furthermore, with the same gas and the same amount of substance, the signal depends on the geometric dimensions of the crucible.

During the melting of a pure substance at a constant heating rate, the first part of the curve (Fig. 2) must be a straight line, the slope of which is proportional to the EMF of the thermocouples. In fact, the value found is lower than the expected EMF. This led us to re-examine the thermal behaviour of a DSC apparatus, to obtain a clearer understanding of the constitution of the apparatus, and consequently, equations describing its behaviour.

EXPERIMENTAL

Calorimeter

A Mettler TA 2000 B calorimeter was used. The measuring system comprised of five differential Au–Ni thermocouples in thin film deposited on a glass disc.

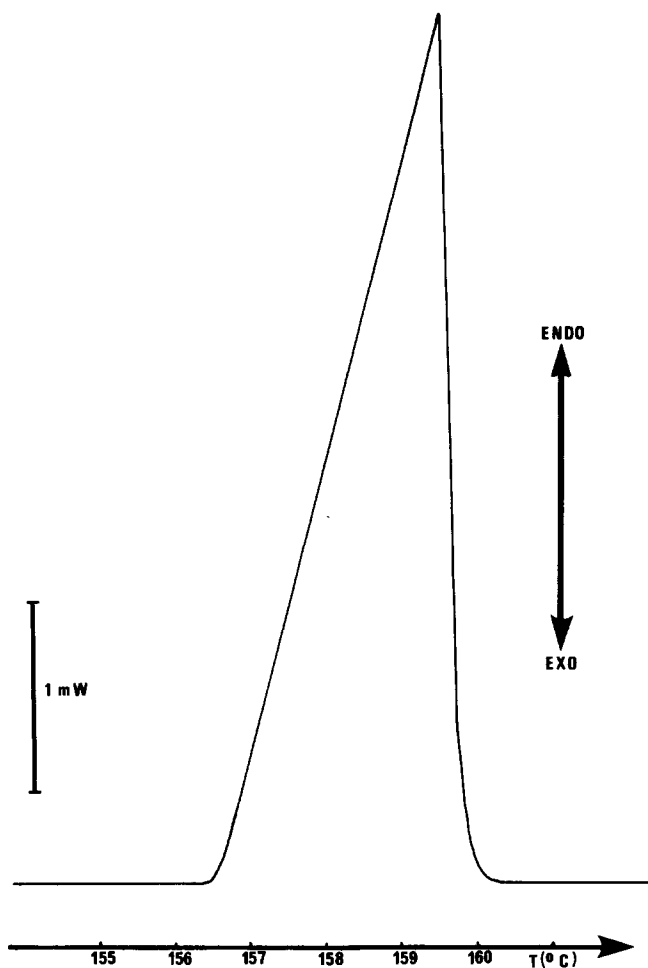

Fig. 2. DSC curve for indium. Sample weight, 19.84 mg; heating rate, $1^{\circ}\text{C min}^{-1}$.

Measurement

A Datron 1051 voltmeter was connected to a Texas SR 60 A calculator and data were recorded. Timing was controlled by a clock at 10^{-2} s [7]. Measurements were made every 5 s.

Qualitative experiments

The calorimeter, flushed with argon at 6 l h^{-1} was set at a constant temperature several tenths of a degree above the melting point of pure indium (purity 99.9999%), which was used as standard throughout the present work ($T_m = 156.61^{\circ}\text{C}$, $\Delta H_m = 3350 \text{ J mole}^{-1}$). There was a reference crucible in the calorimeter but no sample crucible. When the calorimetric

signal was constant a crucible containing a known mass of In was put in place and the signal recorded.

Figure 3 shows a plot of signal vs. time using different reference crucibles (the same amount of In being used each time):

(a) inert crucible containing a calculated amount of Pt in order to have the same heat capacity for both crucibles;

(b) active crucible containing 182 mg of melting In, such that In in the reference crucible is at a constant temperature during the experiment;

(c) active crucible containing 253 mg of the eutectic In–Sb melting about 1.1°C below the melting point of indium. As for In, a sufficient mass of eutectic was chosen. Figure 3 shows that at the same temperature, the signal depends heavily on the nature of the reference crucible. The explanation for this is that some heat exchange occurs between reference and sample.

A very simple description of this phenomenon can be found in the electrical representation given in Fig. 4: heat flows from the furnace E to the sample C_1 or reference C_2 through resistors r , sample and reference being connected through R . The calorimetric signal Δ is the difference in temperature $U_2 - U_1$ multiplied by the sensitivity of the thermocouple g : $\Delta = g(U_1 - U_2)$.

From this first approach, it can readily be seen that the change in

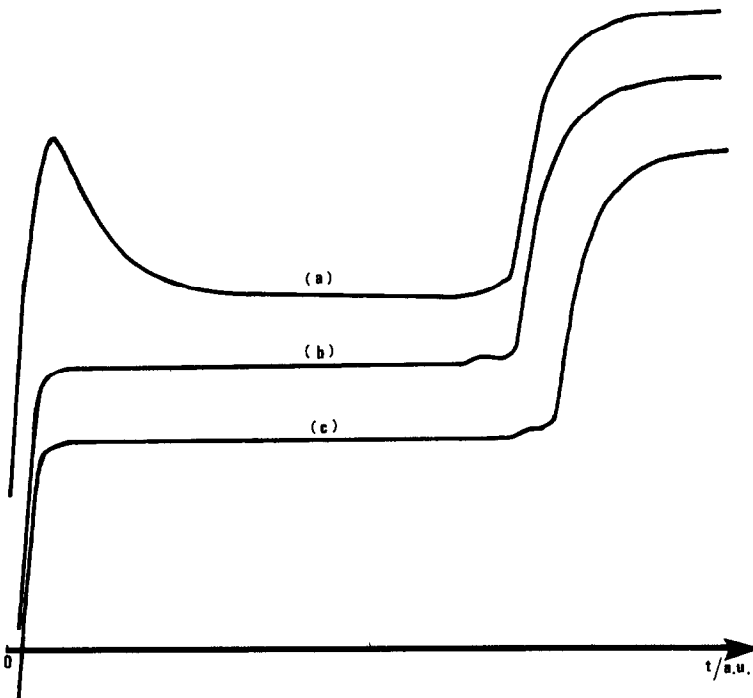

Fig. 3. Calorimetric signal obtained with different reference crucibles. Furnace temperature, 156.80°C ; mass of indium sample, 27.29 mg. (a) In/Pt; (b) In/In; (c) In/In–Sb.

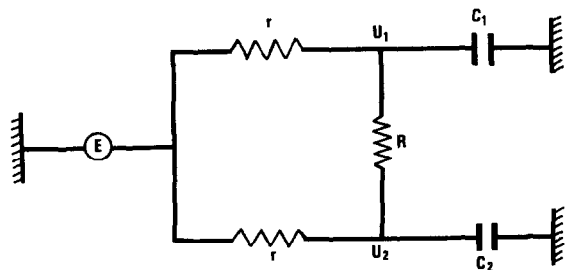

Fig. 4. Electrical representation of the calorimeter. E , heat generator; r , furnace cell resistor; R , sample pan-reference pan resistor; U_2 , sample temperature; U_1 , reference temperature; $C = C_1 = C_2$, heat capacity.

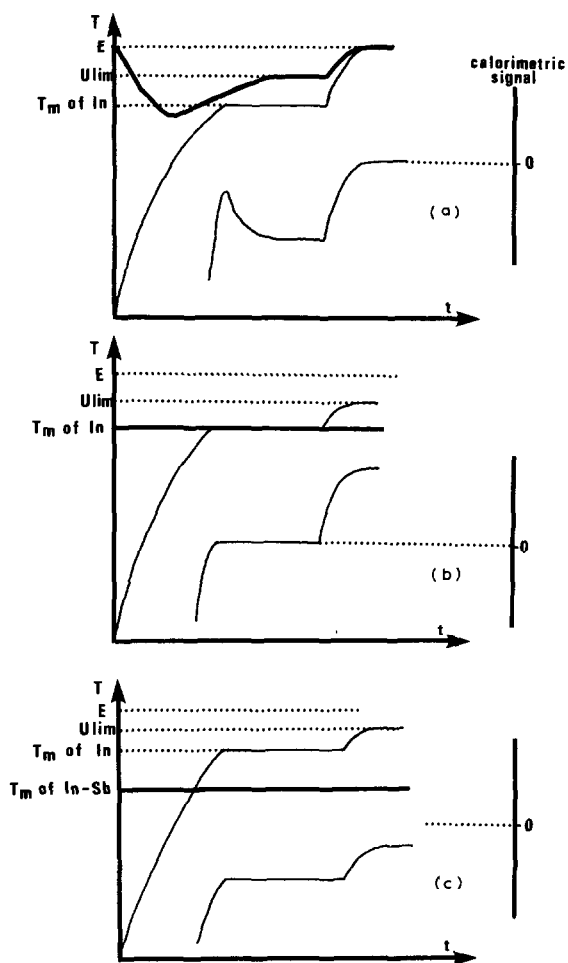

Fig. 5. Evolution of the reference and sample temperatures with different reference crucibles. —, Reference temperature; - - -, sample temperature. (a) In/Pt; (b) In/In; (c) In/In-Sb.

temperature of both crucibles (Fig. 5a, b, c) is completely different, and leads to different calorimetric signals for the same quantity of heat absorbed by the melting of In in the sample crucible.

In experiment (a), the sample crucible cools the reference crucible, then both warm up to the furnace temperature. During the melting of In, the reference crucible has a temperature higher than that of the sample, depending on the values of r and R . After the melting is complete both crucibles return to the furnace temperature E . Calorimetric signal Δ is the difference $g(U_1 - U_2)$ and the overshoot is a natural consequence of the change in temperature of both crucibles. In experiments (b) and (c), since the reference sample is at constant temperature, no overshoot occurs. Heat comes only from the furnace in (b), as opposed to (c) where the same heat flow as in (b) is divided between the reference and In samples. Duration of the melting of In sample is thus longer in (c) than in (b) since In–Sb eutectic melts at a lower temperature than In. The same experiments made using a Dupont calorimeter gave the same qualitative results [8].

Quantitative experiments

For a more detailed and quantitative model of the calorimeter, several experiments have been designed, using only the melting of pure substances, in order to have exactly the same heat transfer as in normal use of the apparatus.

Determination of the EMF of the thermoelements

A Ni–Au–Ni thermocouple was made using 0.2 mm wires purchased from Goodfellow Metals. One thermocouple junction was in a crucible of a Mettler TA 2000 M and the other in a Mettler TA 2000 B. The first was kept at a constant temperature (M) and the other (B) was in heating or cooling mode around the temperature of (M). Heating rate dT/dt was checked using the melting point of pure substances (Hg, C_6H_6 , Na, In, Sn) assuming a linear programme. The signal u was fed into a TA 20 amplifier and recorded.

$$\frac{du}{dt} = g \frac{dT}{dt}$$

where g = the EMF of the thermocouple. The results are reported in Table 1 and agree with the data of Widmann [9]

Influence of the gas on calorimetric sensitivity

In Fig. 4 the resistors r and R vary with the conductivity of the gas in the calorimeter. A crucible containing 74.29 mg of In and a reference crucible containing 136.15 mg of Pt were placed in the apparatus. Using a heating rate of $0.5^\circ C \text{ min}^{-1}$, the peak area, S (in a.u.), due to the heat of melting Q , of the In sample was measured. The results are presented in Table 2. The

TABLE 1
EMF of the thermocouple Au-Ni

$T(^{\circ}\text{C})$	EMF ($\mu\text{V } ^{\circ}\text{C}^{-1}$)
156	26.8
100	24.8
30	21.06

thermal conductivity, λ , was obtained from ref. 12. The following general relation is assumed

$$Q = \frac{g}{\rho} \int_0^t (T_s - T_r) dT$$

with $T = \beta t$, $k =$ arbitrary constant, $T_s =$ temperature of the sample, $T_r =$ temperature of the reference, $\rho =$ thermal resistance furnace crucible, $\beta =$ heating rate, and $t =$ time.

The gas is considered as behaving as a resistor parallel to every thermal resistance (cf. Fig. 4)

$$\frac{1}{\rho} = \frac{1}{\rho_s} + \frac{1}{\rho_g}$$

where $1/\rho_s =$ conductance of the solid, and $1/\rho_g =$ conductance of the gas; thus

$$\frac{Q}{gS} - \frac{1}{\rho_s} = \frac{1}{\rho_g} = k\lambda$$

A plot of $1/S$ vs. λ (Fig. 6) gives a straight line, as expected

$$\lambda 10^5 = 95.8 \frac{10^3}{S} - 16.57$$

TABLE 2
Variation of S with the thermal conductivity of the gas

Gas	$10^5 \lambda$ ($\text{cal cm}^{-1} \text{s}^{-1} \text{K}^{-1}$)	S (a.u.)
Ar	5.665	438.5
N ₂	8.188	386
O ₂	8.466	376
He	47.6	153
H ₂	56.88	130

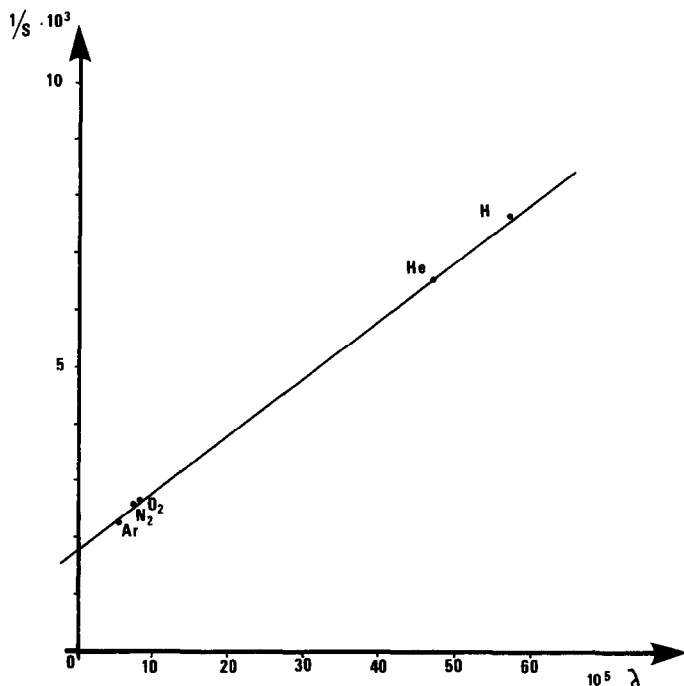

Fig. 6. Influence of the conductivity of the gas on calorimetric sensitivity. Mass of the indium sample, 74.29 mg; $10^3/S = 0.10377 (10^5 \lambda) + 1.7323$.

Determination of heat flow

During the melting of high purity indium, its temperature is constant and if the furnace is at a constant temperature a heat flow, ϕ , enters the sample. But the model of Fig. 4 shows that some heat comes from the reference side. If the reference is at the same temperature as indium, no heat is exchanged between reference and sample. Using the experimental procedure described in the previous section, calling Q the heat absorbed by the melting of the sample, it follows that $\phi = Q/t$. The time duration, t , is simply taken as the beginning and the end of the horizontal line of Fig. 3b. The reproducibility and independence of heat flow vs. mass of the sample was studied and the results are reported in Table 3.

At a constant temperature, ϕ can be measured with a precision of $\pm 1.5\%$. When small masses of indium are used the error is increased due to the difficulty in establishing the precise time duration. Independence of heat flux with mass of the sample demonstrates that a Boersma-type DSC does behave like a conduction calorimeter. Thermal regulation keeps the calorimeter at a temperature constant enough to allow correct measurements.

Influence of temperature on heat flow

Determination of ϕ at several temperatures was carried out using the

TABLE 3

Heat flow vs. mass of sample at constant temperature

$$\bar{\phi} = 3.147 \text{ mW}$$

Mass of In (mg)	t (s)	ϕ (mW)
11.85	114	3.04
19.12	178	3.13
29.8	274	3.18
38.03	355	3.13
48.48	450	3.14
64.36	594	3.16
74.36	682	3.17
86.72	814	3.11
107.27	990	3.16

TABLE 4

Heat flow ϕ and calorimetric signal vs. temperature

T_p (°C)	Mass of In (mg)	t (s)	ϕ (mW)	$\Delta' - \Delta$ (μ V)
156.7	27.12	312	2.537	43.73
156.7	27.12	314	2.521	44.09
156.75	27.12	297	2.665	46.93
156.80	27.12	268	2.954	51.56
156.85	27.12	245	3.231	55.11
156.90	27.12	215	3.682	64.71
156.90	48.39	383	3.688	65.07
156.95	48.39	354	3.990	69.33
157	48.39	320	4.414	75.38
157	48.39	312	4.528	78.22
157.05	48.39	301	4.693	81.78
157.10	48.39	285	4.956	85.33
157.15	48.39	266	5.310	92.09
157.20	48.39	250	5.650	97.42
157.20	27.12	145	5.459	95.64
157.25	48.39	225	6.278	108.53
157.30	48.39	220	6.420	112.71
157.30	27.12	128	6.184	108.44
157.35	48.39	222	6.363	109.87
157.35	27.12	125	6.333	112

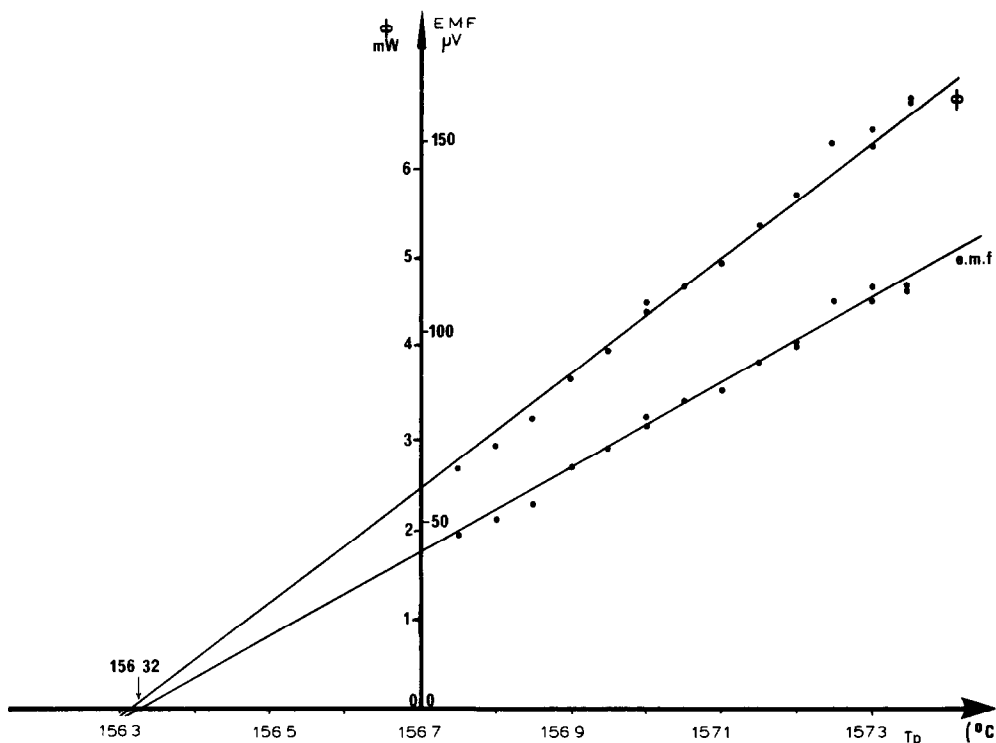

Fig. 2. Influence of the temperature on heat flow.

procedure described under (b) in the previous section. It was not possible to determine the temperature of the calorimeter directly. While the apparatus was at a constant temperature (above T_m of In) a first series of measurements was carried out, then the temperature controller at 0.1 K min^{-1} was switched on for 30 s. A second identical series of determinations was carried out, then a third, and so on. Measurement of ϕ vs. programme temperature, T_p , was obtained assuming each step to be 0.05 K . When In sample and In reference are melting the calorimetric signal Δ is zero. After melting of the In sample, In reference is still melting and the calorimetric signal Δ' depends on the temperature of the furnace, EMF of the thermocouples, and values of the thermal resistors. The results are reported in Table IV and plotted Fig. 7.

Least squares fitting of the curves gives: $\phi = 6.3173 (T_p - 157) + 4.3401$, and $\Delta' - \Delta = 110.42 (T_p - 157) + 75.48$. The lines $\phi = f(T_p)$ and $\Delta' - \Delta = f(T_p)$ intersect the T -axis at nearly the same value $T_p = 156.32^{\circ}\text{C}$, which is the exact temperature of melting of In and a rescaling is therefore possible. Scattering of the data may be due to: (i) non-linearity of the potentiometer giving the value for the temperature controller; (ii) faulty thermal regulation; (iii) thermal equilibrium not reached in the calorimeter.

CONCLUSION

Experimental results obtained with the Mettler TA 2000 BDSC apparatus show that this type of apparatus is a conduction calorimeter with coupled cells such as the model described by Eyraud [10]. It is not possible to neglect the thermal coupling of the cells as assumed by Baxter [11]. From the data given in this paper, a model of a disc-type DSC apparatus will be given in a later paper.

ACKNOWLEDGEMENTS

The authors wish to thank Mr. G. Widmann, P. Wyss and R. Scheidegger of Mettler Instruments A.G., for their support and many valuable discussions.

REFERENCES

- 1 E. Calvet and F. Camia, *J. Chim. Phys.*, 55 (1958) 818.
- 2 E. Cesari, V. Torra, J.L. Macqueron, R. Prost, J.P. Dubes and H. Tachoire, *Thermochim. Acta*, 53 (1982) 17.
- 3 J.P. Dubes, M. Barres and H. Tachoire, *Thermochim. Acta*, 19 (1977) 101.
- 4 E. Cesari, P.C. Gravelle, J. Gutenbaum, J. Hatt, J. Navarro, J.L. Petit, R. Point, V. Torra, E. Utzig and W. Zielenkiewicz, *J. Therm. Anal.*, 20 (1981) 47.
- 5 J. Navarro, E. Cesari, V. Torra, J.L. Macqueron, J.P. Dubes and H. Tachoire, *Thermochim. Acta*, 52 (1982) 175.
- 6 S.L. Boersma, *J. Am. Ceram. Soc.*, 38 (8) (1955) 281.
- 7 P. Claudy, B. Bonnetot, J.M. Letoffe and G. Turck, *Thermochim. Acta*, 27 (1978) 189.
- 8 J. Cattiaux, Dupont de Nemours (France) private communication, 1982.
- 9 G. Widmann, Mettler Instruments A.G. private communication, 1982.
- 10 L. Eyraud and M. Richard, 1st ICTA, Aberdeen, 1965.
- 11 R.A. Baxter, *Proc. 2nd ICTA*, Vol. 1, Academic Press, New York, London, 1969, p. 65.
- 12 L. Medard et al., *Gas Encyclopaedia*, Elsevier, Amsterdam, 1976.